

GL008.06

左旋LH

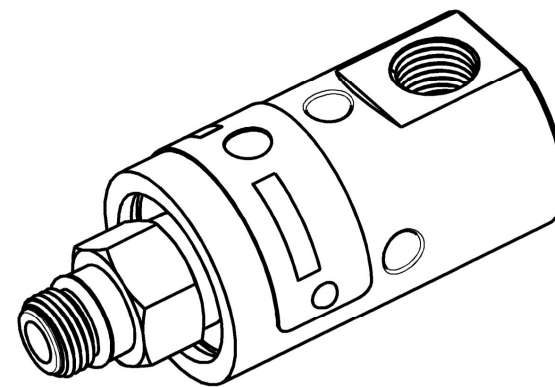
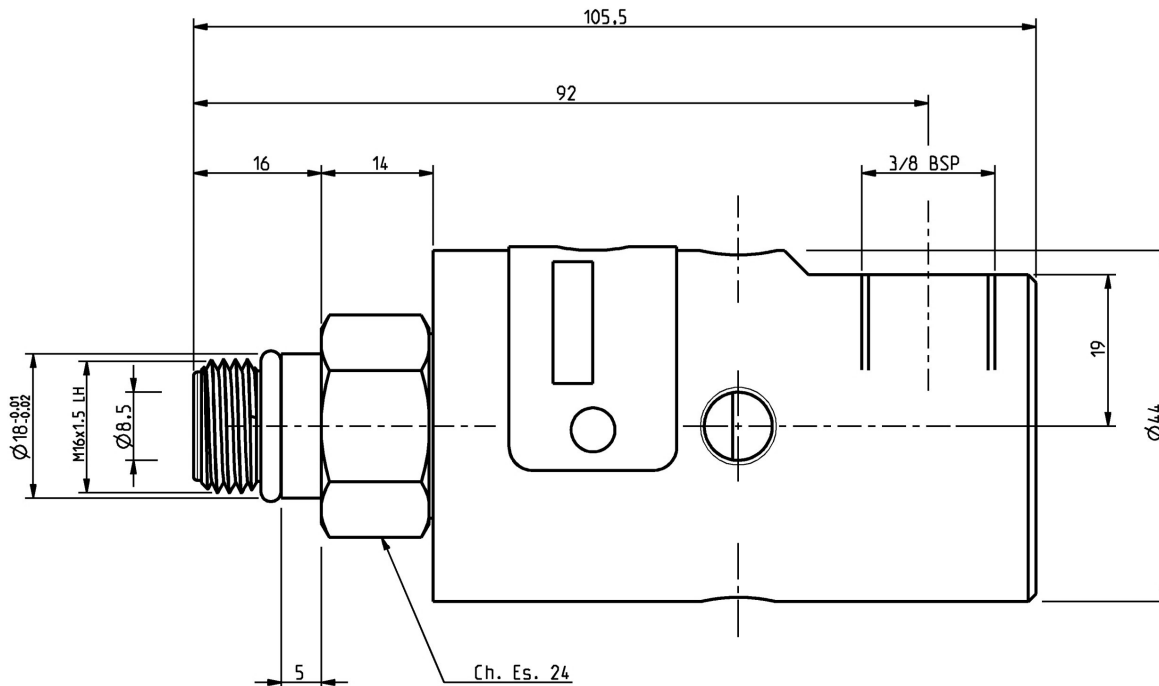
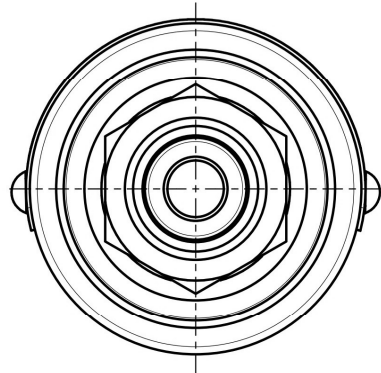

枣庄市德威迩机械科技有限公司

Dewel Machinery Technology Co., Ltd.

技术参数 TECHNICAL PARAMETERS

使用参数 Working parameters

MAX. PRESSURE	7.0MPa; (<70Bar)
MAX. SPEED	10000RPM;
TEMPERATURE	-20℃----+70℃
MEDIA TYPE 介质	Water/cutting fluid/compressed air/ oil 水/切削液/压缩空气/液压油

介质 Fluid	压力 Pressure	温度 Temperature	转速 Rotating speed
空气 Air	2.0MPa:	-20℃----+70℃	3000RPM
水 Water	7.0MPa:		10000RPM

High precision bearings to be free from constant maintenance.  
Multi-spring design for optimized spring compensation effect.  
Anti-impurity sealing structure.  
Labyrinth water-proof sealing design that avoids bearing failure during vertical operation.

备注：技术参数数据为最大值，并不能同时使用；

The technical parameter data is the maximum value and cannot be used at the same time.

旋转接头  
Rotary joint  
E-mail: sddeweier88@163.com



www.sddeweier.com

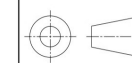

TEL: +86 632 5822778  
TEL: +86 632 5832779

P/N: GL008.06